



SERVICE INSTRUCTIONS



**DUAL OCTO
SECOND STAGE REGULATOR
SR 7206**

INTRODUCTION

The instructions set forth in this document are intended to guide the experienced scuba equipment repair technician through the standard service procedure for the Dual Octo second stage regulator.

It is assumed that the technician possesses basic scuba equipment repair training and the skill necessary to perform the service. If you have not received regulator service training as an Authorized Sherwood Scuba Dealer do not attempt to perform the service described in this document. If you are uncertain as to whether you are qualified to perform this service contact your regional Sherwood Scuba Distributor for advice.

GENERAL INSTRUCTIONS

Special Notations



WARNING: Indicates a potentially hazardous condition or situation which, if not avoided, may result in serious injury or death.



CAUTION: Indicates a potentially hazardous condition or situation which, if not avoided, may result in minor or injury. It may also be used to alert against unsafe practices.



NOTE: Indicates an important point or reminder.

When to service

Generally the Dual Octo should be inspected for service at least annually. If the regulator has been subjected to less than 100 hours of use it may just require a routine inspection not necessarily requiring the replacement of parts.

If the regulator has been subjected to more than 100 hours of use or it has not received the benefit of careful post-dive cleaning and storage in a clean environment, the regulator should receive standard service. Standard service includes cleaning, inspection for damaged parts, replacement of seals and the valve seat, reassembly and adjustments.

Dual Octo regulators that are subjected to extreme conditions such as daily use or infrequent cleaning may need service more frequently depending on inspection results.

Sherwood Scuba offers a standard service kit (P/N 6000-9) that contains the parts that should be replaced at the standard service interval.

Use only authorized parts and lubricants. Substitution of parts other than those available from Sherwood Scuba may cause the regulator not to perform as intended by the manufacturer and will void the warranty.

Working conditions

Service should be performed in a well lighted, clean area with access to proper tools. Use of improper tools or techniques may cause permanent damage and void the warranty.

Service Procedure

The standard service procedure involves disassembly, inspection, cleaning, reassembly and adjustment of the regulator. As each step of the process is performed check the parts for damage or distortion. Replace parts that appear to have sustained damage.

Cleaning can normally be performed by rinsing with the aid of mild detergent and a soft brush followed by a thorough rinsing with fresh water. Use of an ultrasonic cleaner and commercially available solutions can accelerate this process. Be certain to check with the supplier of the solution for compatibility with respiratory equipment. Thorough rinsing should always follow the use of any cleaning agents.

O-rings should be lightly lubricated with Crysto-Lube MCG 111 before installation. Avoid the use of silicone spray or other lubricants containing hydrocarbons.

Disassembly

1. Pull back the hose protector (26) and inspect the hose for signs of cuts, cracks or other damage. A damaged hose should be replaced.
2. Remove the Dual Octo assembly from the first stage regulator at the hose connection with a 9/16" (14 mm) wrench.
3. Use a 3/4" (19 mm) wrench to support the Inlet Fitting (1) and 5/8" (16mm) wrench to separate the swivel end of the hose from the Inlet Fitting. Do not allow the Inlet fitting to rotate within the Housing (10), as this may cause damage to the Housing.
4. Inspect the o-rings (18 and 20) at the both ends of the hose for signs of wear or damage. If these are damaged they should be replaced. Use only a nonmetallic or a soft brass instrument to remove the o-rings. Use of other tools and carelessness may cause damage to the sealing surfaces on the hose fittings requiring replacement of the entire hose. Sherwood does not recommend replacement of the o-ring at the swivel end of the hose if it does not show evidence of wear or damage.
5. Remove the Mouthpiece (12) by cutting the Mouthpiece Strap (13) with side cutting pliers. Be careful not to cut or damage the Mouthpiece. Discard the strap and examine the Mouthpiece for cuts or tears. If there is damage it should be replaced.
6. Remove the Cover Ring (24) by unthreading it from the Housing by hand. Tools should not be necessary and could cause damage to the Cover Ring. If it is difficult to remove, soak the entire regulator in warm water for a few minutes to loosen mineral deposits. Remove the Purge Cover (23) and Diaphragm Retainer (22).
7. Gently remove the Diaphragm (21) from the Housing. Hold the Diaphragm up to a light source and gently stretch to search for tears or pin holes. If any are found replace the Diaphragm. If it is undamaged it may be reused.

- Before further disassembly check the alignment of the Demand Lever (7) with regard to the Housing (10). The surface of the Demand Lever that contacts the Diaphragm should be parallel to the Housing within 1/16 inches. Place a straight edge across the Housing to check the alignment of the Demand Lever. (Refer to Illustration 1). If the Demand Lever is above or below the edge of the Housing, it usually can be adjusted later as long as the surfaces are parallel. If the Demand Lever is distorted, it should be replaced.

If the Lever Support (6) rotates within the Housing and causes the Demand Lever to deviate from a parallel position with regard to the Housing, check the Housing indexing feature for damage after the Lever Support is removed from the Housing. Damage of this type is generally caused by improper tightening of the LP Hose fitting without supporting the Inlet Fitting.



1) *Checking alignment of Demand Lever*

- Use a wrench to remove the Inlet Fitting (1) from the Housing. Remove and discard the o-ring (2) using a nonmetallic or soft brass instrument to avoid damage to the sealing surfaces of the Inlet Fitting.



NOTE: Deep scratches on metallic sealing surfaces may interfere with sealing and require replacement of the part.

- Gently remove the demand valve subassembly from the Housing as a complete subassembly. (Refer to Illustration 2) This subassembly consists of the Lever Support (6), Lever (7), Washer (8), Locknut (9), Spring (5), Poppet (4) and Seat (3). In most cases it is unnecessary to further disassemble the demand valve subassembly if it is free of corrosion or mineral deposits and the lever will move the poppet smoothly. If this is the case, then remove and discard the Seat (3). This may require the use of a straight pin or needle to pierce and extract the Seat. Be careful not to damage the metallic surfaces around and under the seat.



2) Demand Valve Subassembly

11. If the subassembly shows salt or other mineral deposits that prevent the poppet from moving smoothly, it should be cleaned as an entire unit using an ultrasonic cleaner with a mild cleaning agent. If this fails to remove the deposits, the demand valve subassembly should be disassembled by unthreading the Lock Nut (9) from the Poppet (4). The disassembled parts may then be soaked in a mild solution of 50% white vinegar and scrubbed with a medium soft brush to remove deposits.
12. Remove the mouthpiece Boss Retaining Ring (15) using snap ring pliers with 45 degree angled cylindrical tips. Use of this tool enables you to spread the Retaining Ring and slip it over the Mouthpiece Boss (11). Remove and discard the o-ring (14). Gently clean the o-ring groove on the Mouthpiece Boss and inspect the groove for cuts, deep scratches or other damage. Replace it if it is damaged.
13. Remove the Exhaust Valve Cover (16) on each side of the Housing by grasping the cross bars on the cover by hand and gently unthreading. Gently remove each Exhaust Valve (17) by grasping the valve with the fingers and folding it in half. (Refer to Illustration 3). With the other hand grasp the stem of the valve and gently stretch it. This will allow you to pull the valve away from the Housing to remove it. Clean the surface of the housing where the Exhaust Valve seats. Inspect the seating surface under the valve for nicks, cuts or other damage that may prevent sealing of the exhaust valve. If these surfaces are damaged the Housing must be replaced. The valves are made of a durable material and should not require replacement unless they show signs of damage.



3) Removal of Exhaust Valve

14. Clean and rinse all parts in preparation for reassembly.

Reassembly

15. Install the Exhaust Valves using the same gentle stretching technique used for removal.
16. Install each Exhaust Valve Cover using only your fingers to tighten. Use of tools may damage the Exhaust Valve Cover.
17. If the demand valve subassembly was cleaned as a unit and not further disassembled install a new LP Seat (3). Do not attempt to use an old seat as the impression in the old seat may prevent adequate sealing.

If the subassembly was disassembled, then place the Poppet (4) on a flat surface with the face the Poppet against the flat surface. Place the Spring (5) over the poppet stem and then place the Lever Support (6) over the Spring. Press down on the Lever Support taking care to match the square feature on the poppet stem with the matching square hole in the Lever Support. When the square features are aligned you will be able to compress the Spring until the Lever Support makes contact with the supporting flat surface. While maintaining the applied force on the Lever Support, insert the Demand Lever as shown in Illustration 4. Use your fingers to hold the Demand Lever in place and add the stepped Washer (8) to the subassembly with the smallest diameter making contact with the Demand Lever.

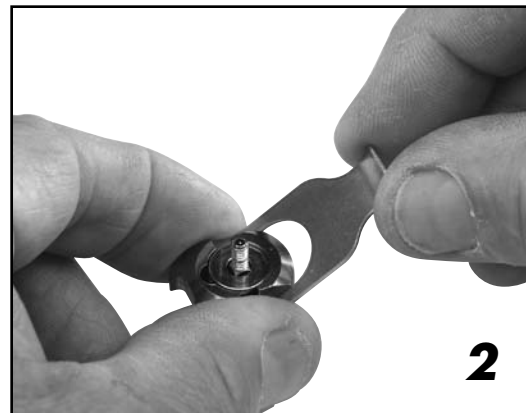
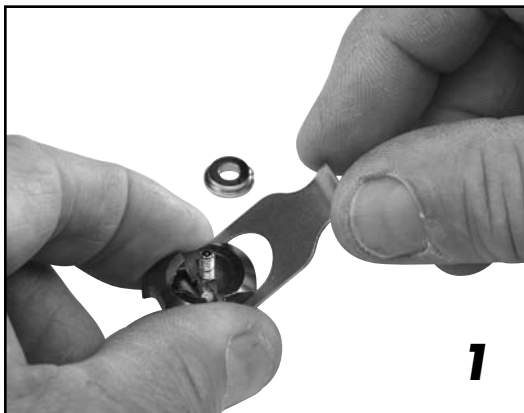

4) Compress the Spring against a flat surface and add the Demand Lever and Washer to the subassembly.

Thread the Lock Nut (9) onto the Poppet just until the end of the poppet shaft starts to protrude from the end of the Lock Nut. The Lock Nut may be reused for several repeated services, but if it has been used to the extent that it rotates with very little resistance or will not stay in position it should be replaced.

Install a new Seat into the Poppet.

18. Inspect the crowned seating surface inside the Inlet Fitting for nicks, deep scratches or other signs of damage. Light corrosion may be removed with a pencil eraser. Do not attempt to polish with abrasive materials. If it is damaged it should be replaced. Install o-ring (2) onto the Inlet Fitting.
19. Insert the demand valve subassembly into position inside the Housing taking care to align the indexing notch with the block feature in the Housing. If these parts cannot be aligned, check to be certain the Demand Lever is not installed upside down.

20. Hold the demand valve subassembly in place and install the Inlet Fitting. Hand tighten (approximately 40 in lbs). As the Inlet Fitting is installed the Demand Lever position will change and it will be loosely retained until the final adjustment is made.
21. Use the nut driver to tighten the Lock Nut until the Demand Lever rises to be level with the top of the Housing.
22. Install the LP Hose (19) onto the Inlet Fitting. Be certain to secure the Inlet Fitting with a wrench as the hose fitting is tightened (40 in-lbs).



CAUTION – Rotation of the Inlet Fitting within the Housing will damage the indexing feature and may cause the Demand Lever to misalign. This could compromise regulator performance and will require replacement of the Housing.

23. Attach the LP Hose to the first stage regulator and torque to 40 in lbs.
24. The Dual Octo is designed to be compatible with regulators that operate with an intermediate pressure ranging from 120 to 150 PSI. If the first stage is not operating within these pressures, the Dual Octo may not perform properly. If necessary, service the first stage regulator so that it operates within these pressures or match the Dual Octo to a first stage that does operate within the prescribed limits.
25. Apply pressure to the regulator assembly and tighten the Lock Nut until a very slight leak is presented. Loosen the Lock Nut slowly until the leakage stops. Continue loosening approximately 1/8 turn. The Demand Lever should be aligned with or slightly below the surface of the top of the Housing and should allow slight movement of the lever without opening the valve. If the correct alignment is not present continue loosening the Lock Nut until alignment is achieved, but do not loosen the Lock Nut more than 1/4 turn past the point where leakage is stopped. If alignment cannot be achieved it is likely the Demand Lever is distorted and must be replaced.
26. Install o-ring (14) on to the Mouthpiece Boss.
27. Install the Mouthpiece Boss into the Housing noting the desired orientation of the Mouthpiece. There are two positions available and the selection should match the user's choice. Use snap ring pliers to spread the Retaining Ring (15) and position it over the groove on the Mouthpiece Boss. After the Retaining Ring is released, check to verify that it contained in the groove. Pull on the Mouthpiece Boss to check retention.



WARNING – Failure to properly secure the Mouthpiece Boss to the Housing may result in separation during a dive. If this were to occur the diver may be exposed to inhalation of water causing a potentially hazardous condition requiring an appropriate emergency response to avoid serious injury or death.

28. Install the Mouthpiece (12) and secure with the Mouthpiece Strap (13).
29. Install the Diaphragm, Retainer and Purge Cover with the Sherwood logo aligned parallel with the axis of the Inlet Fitting.

30. Install the Cover Ring and hand tighten until there is no gap between the Housing and the Purge Cover.

Final Check

31. With pressure applied to the regulator assembly immerse the entire regulator to check for air leaks. Air leaks are most commonly caused by damaged or contaminated o-rings. Repair or replace as necessary.
32. Release the pressure from the regulator assembly keeping the assembly mounted to the closed cylinder valve. Apply a vacuum to the Dual Octo until movement of the diaphragm is detected. Stop applying the vacuum and observe whether air is leaking back into the Housing. Sources of leakage must be corrected and are usually traceable to a damaged or improperly installed a) Diaphragm, b) Mouthpiece or Mouthpiece Boss or c) Exhaust Valves.



WARNING – If the sources of leakage into the Housing are not resolved the user may be exposed to entrance of water into the regulator while diving. If this is not treated with an appropriate response the user may become stressed and subject to risk of serious injury or death.

33. Pressurize the regulator and depress the purge to verify that a strong flow of air is available. If the flow is slight, the position of the Demand Lever is probably the cause and a correction should be made. Repeat Step 25 or replace Demand Lever if necessary.
34. If a regulator test bench is available check to verify that the cracking pressure is between 0.75 and 1.5 inches of water. If no bench is available, cracking pressure can be verified by slowly immersing the pressurized Dual Octo with the mouthpiece in an upward position. The regulator should begin to deliver air when the Diaphragm is 0.75 to 1.5 inches below the surface of the water. Be certain to allow the regulator to completely dry before storing in a closed container.

WARRANTY INFORMATION

The Dual Octo Regulator is warranted against manufacturing defects for a period of two years from the date of purchase from an Authorized Sherwood Dealer. Warranty extends only to the original purchaser of the product and is not transferable. Warranty services requires proof of purchase. Keep your sales receipt to present as proof of valid purchase. Warranty is limited to repair or replacement at the discretion of Sherwood Scuba.

In addition, as an original owner of the Dual Octo Regulator you may be eligible to receive two sets of standard service parts provided that service is performed by an Authorized Sherwood Dealer. Service labor is not included and is the responsibility of the product owner. The Hose Protector on the Dual Octo has two removable plastic rings. Each ring may be redeemed for a standard service parts kit (P/N 6000-9) at the time service is performed. Please see your Authorized Sherwood Dealer for details.

PETER SKOP INDUSTRIES

6161 Atlantic Blvd.
Norcross · Georgia 30071
Toll Free: 800-774-4447
TL: 770-449-4141
Toll Free FX: 800-849-4774
FX: 770-242-0683

DIVERSCO

495 Conestoga Blvd.
Cambridge · Ontario N1R 7P4
Toll Free: 800-650-0061
TL: 519-740-1210
Toll Free FX: 877-264-3920
FX: 519-740-9051

CRAMER DECKER INDUSTRIES

1641 E. St. Andrew Place
Santa Ana · California 92705
Toll Free: 800-347-9766
TL: 714-566-3820
: 714-566-3839



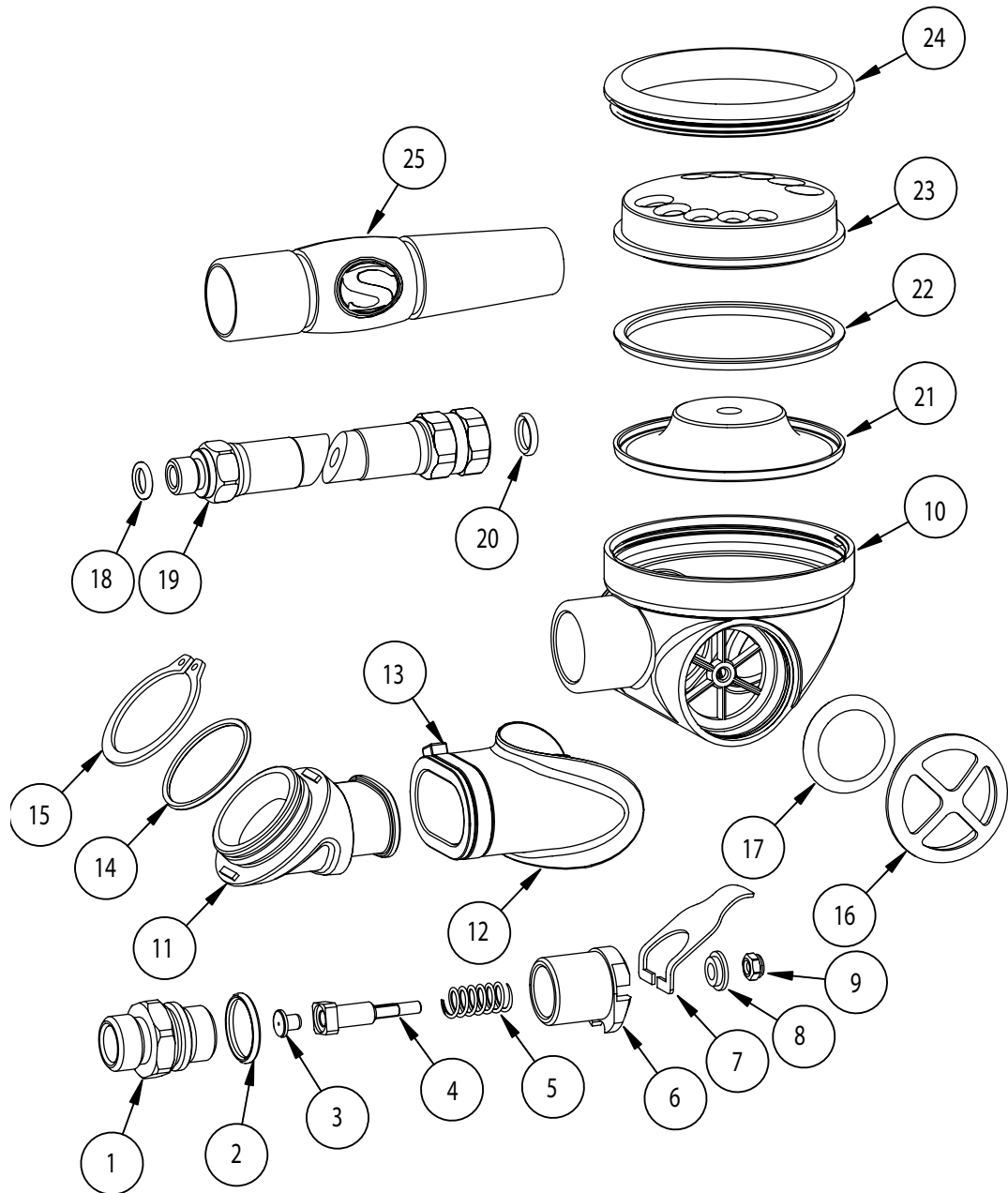

Item	Qty.	Part No.	Description
1	1	1-7206-7	Inlet Fitting
2	1	G015B	O-ring
3	1	7206-9BN	LP Seat
4	1	9-7206-18	Poppet
5	1	19-7206-29	Spring
6	1	9-7206-9	Lever Support
7	1	7206-10	Lever
8	1	7206-73	Washer
9	1	7206-71	Locknut
10	1	7206-5	Housing
11	1	7206-2	Boss, Mouthpiece
12	1	7206-3	Mouthpiece
13	1	7206-1	Strap, Mouthpiece

Item	Qty.	Part No.	Description
14	1	G020-B	O-ring
15	1	7206-68	Retaining
16	2	7206-8	Cover, Exhaust
17	2	7206-15	Valve, Exhaust
18	1	G011B	O-ring
19	1	7206-50-36	Hose, Octo, LP
20	1	G010A	O-ring
21	1	7206-4A	Diaphragm
22	1	7206-6	Retainer
23	1	7206-23	Purge Cover
24	1	7206-24	Cover Ring
25	2	SWC01	Warranty Ring
26	1	7206-27	Hose Protector



WARNING

Use only Sherwood Scuba parts! Use of other manufacturer's parts will void all warranties and could result in air delivery failure, causing serious personal injury or death.



www.sherwoodscuba.com